

SP 500

Trailer-Mounted
Concrete Pump



THE CONCRETE, SHOTCRETE OR GROUT PUMP

- Output to 45 cubic yards per hour
- Pressure to 1100 psi
- 1.5" Maximum Aggregate Size

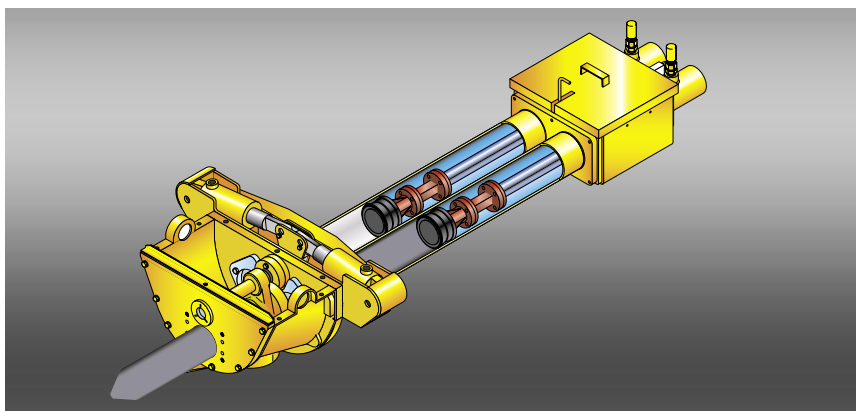

This open loop, all-hydraulic concrete pump sets the standard for fuel-efficiency, reliability and performance. Twin circuit hydraulics combine with standard dual shifting cylinders, agitator and Long Rock Valve™ to provide smooth pumping of harsh mixes, shotcrete and grout.



Convenient control panel includes electric switches for on/off, forward/reverse and agitator on/off. Tachometer and hour meter are also located here along with E-stop, fuse panel and ignition switch.



Invest in an all-hydraulic concrete pump that incorporates big pump features into a compact, economical package. The SP 500 is an excellent entry-level, all-around performer pumping grout, shotcrete and structural concrete horizontally and vertically with output to 45 yards per hour and 1100 psi.

This full range of capabilities means high utilization of your pump and fast return on your investment when you say “Yes” to the majority of projects. One call to a Schwing dealer or company store puts you in touch with pumping expertise and a full range of accessories so you are ready for new pumping challenges and profits.

Because your SP model is patterned on larger Schwing models, you are guaranteed legendary reliability that has been proven on thousands of projects. Whether your pump is your livelihood or part of a larger equipment fleet, purchase with the confidence that only a Schwing can provide.



Remote control (cable or optional radio remote) frees the operator to monitor the end hose and the pump. Critical functions including on/off and forward/reverse are at your fingertips.



*Fuel efficient **Deutz diesel** is an example of the high quality components on our trailer pumps. Here is an engine that was designed for construction applications and is up to the reliability standards of a Schwing pump.*



*Fast cleanout with less wasted concrete is a benefit of the SP 500 over other pumps. The standard **hopper agitator** keeps harsher mixes flowing to the Rock Valve™ for trouble-free pumping.*

Only one manufacturer can supply the Schwing experience.

Thousands of our customers form a backdrop of success that you can join by letting us spec the right piece of equipment for your needs. Six company stores with technicians and parts placed strategically across the country provide service expertise as close as your phone. And a select group of knowledgeable dealers provides another layer of invaluable experience. You and your staff will be welcomed into our facility to learn how to extract the maximum profitability from your concrete pump.

Generations of successful owners have chosen the Schwing experience. As a third generation family owned company we understand how important quality equipment is to your business and how important your business is to us.



The stationary pump plant in Atlanta is a modern model of efficiency, manufacturing pumps in trailer, skid or truck-mounted configurations for applications around the world. From close inspection of incoming materials to forming our products with the latest production processes, Schwing takes craftsmanship to the highest standards. Vigorous testing of every unit prior to shipment is your assurance of reliable pumping. In addition, a vast inventory of parts are on hand to keep your Schwing product running at maximum efficiency. Please schedule a visit to this modern facility located just north of Atlanta to see our long-term commitment to the global market.

SPECIFICATIONS

PUMP SPECIFICATIONS

	U.S.	Metric
Concrete Output Per Hour (cubic yards-cubic meters)	45	35
Maximum Pressure on Concrete (psi-bar)	1100	76
Maximum Aggregate Size (in.-mm)	1.5	38
Maximum Horizontal Pumping Distance* (feet-meters)	1160	354
Maximum Vertical Pumping Distance* (feet-meters)	330	100
Concrete Cylinder Diameter (in.-mm)	6	150
Differential Cylinder Diameter (in.-mm)	3.14/1.97	80/50
Concrete Cylinder Stroke Length (in.-mm)	39	1000
Maximum Pump Strokes Per Minute	32.5	32.5
Main Hydraulic Pump	A11V095	
Volume Control	0 to Maximum	
Concrete Valve Type	Long Rock™	
Shifting Cylinders	2	
Hydraulic Tank Capacity (gallon-liters)	50	190
Hydraulic System	Open Loop	
Hopper-Height (in.-mm)	48	1220
Hopper Capacity (cubic feet-cubic meters)	11	.31
Outlet Diameter (in.-mm)	5	125
Engine Model - Tier II	Deutz BF4L2011	
Engine Model - Tier III	Deutz TCD2011 L04i	
Engine Power (horsepower-kilowatt)	72	54
Fuel Tank Capacity (gallon-liter)	20	75
Axle	Single Standard	
Axle Capacity Rating (pounds-kilograms)	6000	2722
Tires	ST 235/80 R16	
Brakes	Electric	
Outrigger Legs	Manual Standard	
Length (in.-cm)	166	422
Width (in.-cm)	66	168
Height (in.-cm)	76	193
Trailer Units Weight (pounds-kilograms)	5500	2495
Remote Control Cable (feet-meters)	100	30

*Pumping distances shown are to be used as a guide only since they have been considerably exceeded on specific projects. Maximum attainable distances depend upon concrete mix design and pipeline diameter. Maximum output and distance cannot be achieved simultaneously.

**Pump specifications are for standard units. Other units are available.
Specifications are subject to change without prior notice.

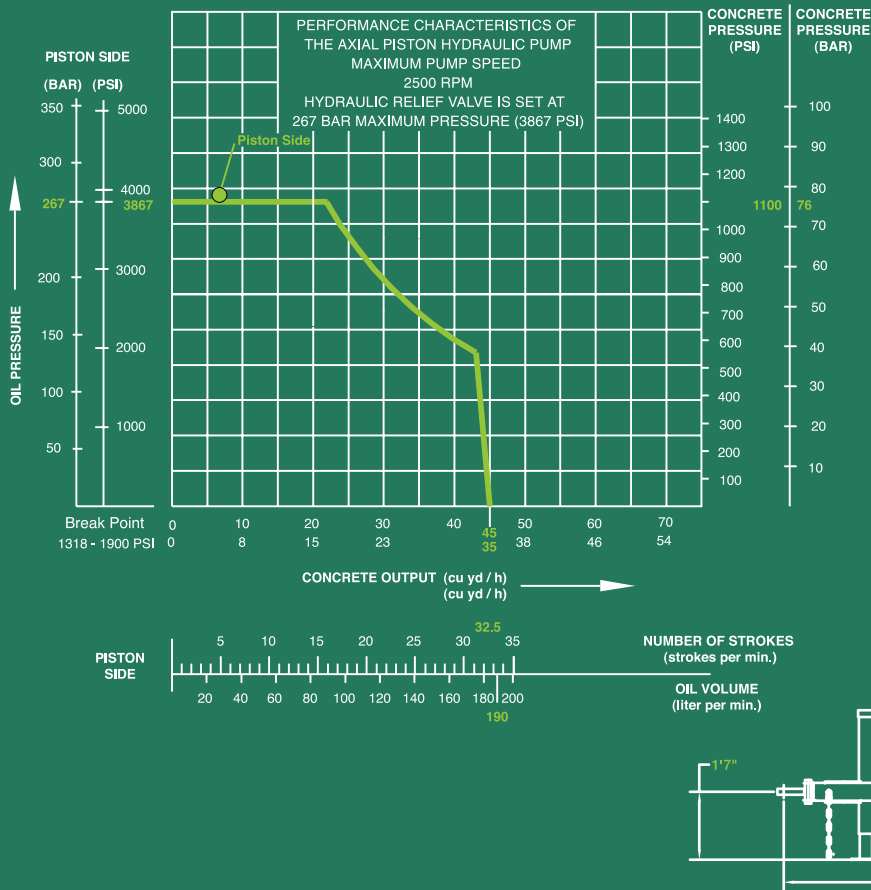

SCHWING-STETTER MOVES CONCRETE. **WORLDWIDE.**

Wherever concrete is produced and moved is where you will find Schwing-Stetter machinery.

With plants in Germany, Austria, USA, Brazil, Russia, China and India as well as with more than 100 sales and service facilities, the group of companies is always close to the customer.

Our wide range of products with something for every application is what makes Schwing-Stetter the No. 1 system supplier for concrete machinery worldwide.



CONCRETE BATCHING PLANTS



TRUCK MIXERS



TRUCK-MOUNTED CONCRETE PUMPS



STATIONARY CONCRETE PUMPS



SEPARATE PLACING BOOMS



CONCRETE RECYCLERS